



WEBINAR

Cables 101

October 26, 2021

By: Wissam Geahchan, Applications Engineer



ATTENTION

AUDIENCE PARTICIPATION

- **Questions can be asked at any time using the chat function on the webinar screen**
- **Any unanswered questions will be followed up through email**
- **This presentation, a recording of the webinar and a brief survey will be emailed to all registrants**

Wissam Geahchan



Applications Engineer, Nexans Canada

- **Electrical Engineering graduate from the University of Toronto**
- **Member of the CSA Integrated Committee for Wire and Cable (ICWC)**
- **Member of UL STP 1072 - Medium Voltage Power Cables**
- **LEED Green Associate**
- **Soccer coach**



AGENDA

- Fundamentals of Electricity and Electrical Systems
- Basics of Wire and Cable Construction
- Copper vs Aluminum
- Selecting the Right Cable for your Applications
- Cable and Wire Alternatives
- Key Takeaways
- Q&A

Nexans is a global leader with a long legacy in Canada



Weyburn, SK

Fergus, ON

Montreal, QC



1911  **canada[®]
wire**

Started with Canada Wire in Toronto, ON

3 Plants

750+ Products

- Residential, Commercial, Industrial & Utility
- Copper Rod & Wire



Nexans Canada – Standard Product Portfolio



Residential

- Bare Copper
- CANADEX® NMD90
- HEATEX® NMD90
- SUPERVEX® NMWU

Commercial

- AC90
- CORFLEX® Armoured Cu & Al
- INSTAGLIDE® RW90 & RWU90 Cu & Al
- INSTAGLIDE® T90 Nylon Cu & Al
- TWU

Renewable Energy

- RPVU90 2 kV Cu & Al
- ENERGEX® Medium Voltage 90°C 15 to 46 kV
- ENERGEX® Medium Voltage 105°C
- ACSR

Industrial

- ACWU90
- CP-100 Railway Signal
- DriveRx® VFD
- FIREX® TECK90 – 600 V, 1 kV & 5 kV
- FIREX® Medium Voltage Armoured Power Cable

Transmission/Distribution

- Bare ACSR & AACSR
- Bare Aluminum & Al Alloy
- Covered Overhead Distribution Line Wire
- ENERGEX® CN & SP Medium Voltage
- NS75 & NS90
- Street Light Cable
- USE175 & USE190 & USEB90

Copper Rod & Wire

- Copper Rod
- Copper Wire



Industry Education

Our Previous Webinar Recordings

- **Raw Materials Insights with Dow** - click [here](#) to watch it
- **Renewable Energy Trends** – click [here](#) to watch it
- **Emerging Trends for Utility Cables** – click [here](#) to watch it
- **Key 2021 Electrical Code Changes Impacting Wire and Cable** – click [here](#) to watch it
- **15 kV Medium Voltage Armoured Cables** – click [here](#) to watch it
- **Connected Drums - Nexans Canada's Reel Tracking Solution** – click [here](#) to watch it
- **DriveRx® VFD Cable 2.0** – click [here](#) to watch it
- **CORFLEX®** – click [here](#) to watch it
- **Prior VFD webinar** – click [here](#) to watch it

Nexans: Contributing to Carbon Neutrality by 2030



What is Electricity?

- Form of **energy**. It can occur naturally and can also be produced and maintained
- Expressed in terms of the movement and interaction of electrons.



Useful Terms



Voltage, Current and Power

Voltage:

- Force (or push) that moves electrons in a common direction through a material
- The greater the voltage, the greater the pressure
- Unit is volts (V)

Current:

- Rate of flow of electrons through a conductor
- Current flows when electrons are pushed by the force of an applied voltage
- The greater the current, the greater the rate of flow of electrons
- Unit is amperes or amps (A)

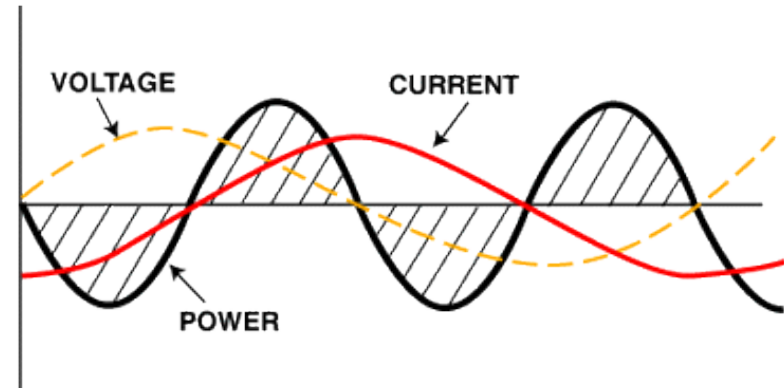

Insulated wire is like a garden hose

- Water (electrons) is pushed through the hose (conductor) by the pressure (voltage) from the pump (generator)
- Higher the pressure (voltage) from the pump (generator), the thicker the hose (insulation) needs to be to withstand the pressure (voltage)
- Higher the volume of water (electrical current), the larger the diameter of the hose (conductor cross sectional area)

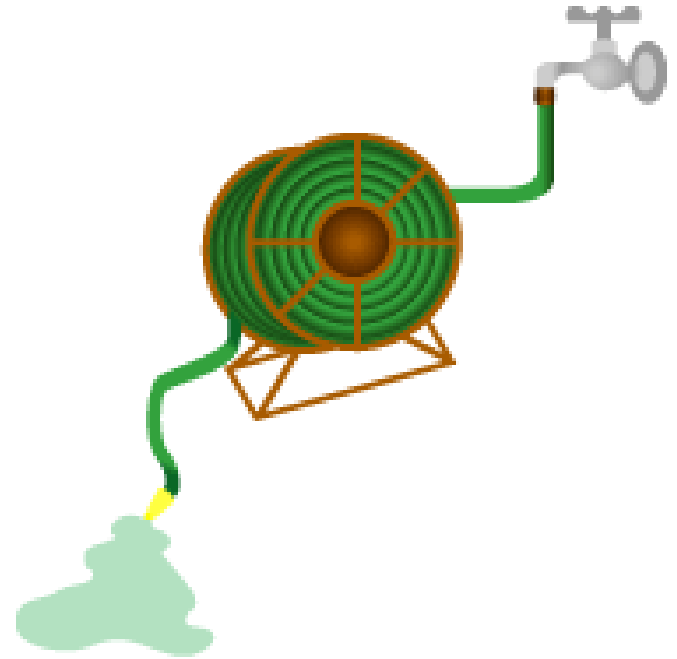

What is Electric Power?

- Rate at which electrical energy is transferred by an electric circuit
- Unit is watt (W)
- **Real power (P)** = Portion of power flow that results in net transfer of energy in one direction
- **Reactive power (Q)** = Portion of power flow due to stored energy that returns to the source in each cycle
- **Apparent power (S)** = Vector sums of these powers
- Electrical engineers use the apparent power when designing and operating power systems
- Conductors, transformers and generators must be sized to carry the total current, not just the current that does useful work

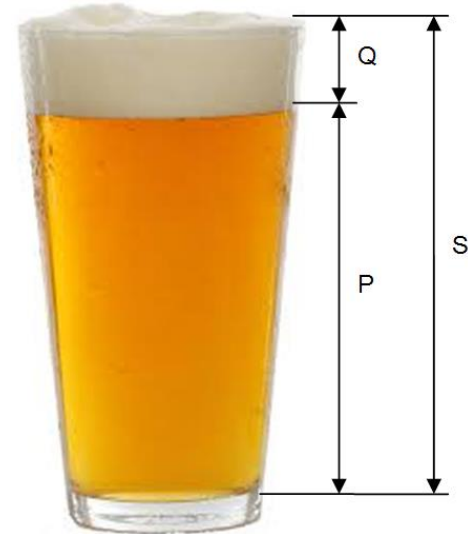
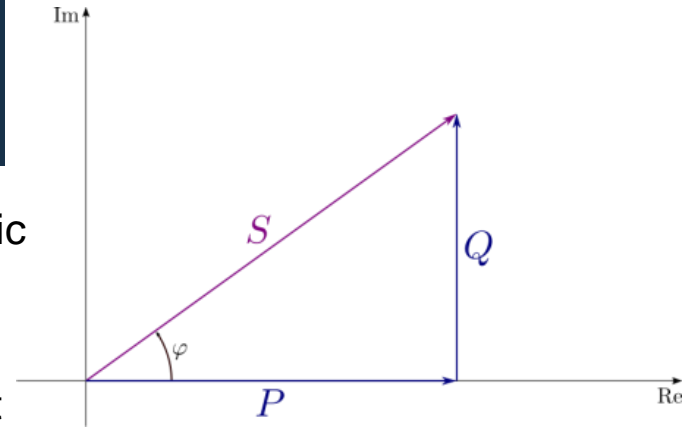

Electrical Systems

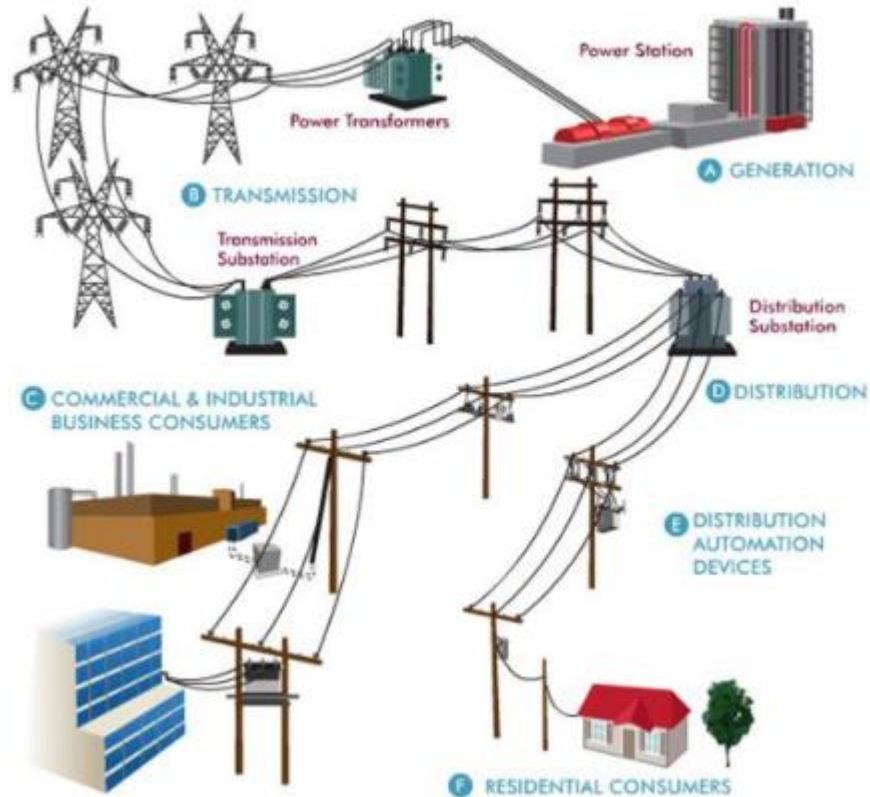

1-Phase Systems

Most often used in homes or small businesses, where the power requirements are low – typically up to 72 kW (300 A service, with a 120V / 240V system).

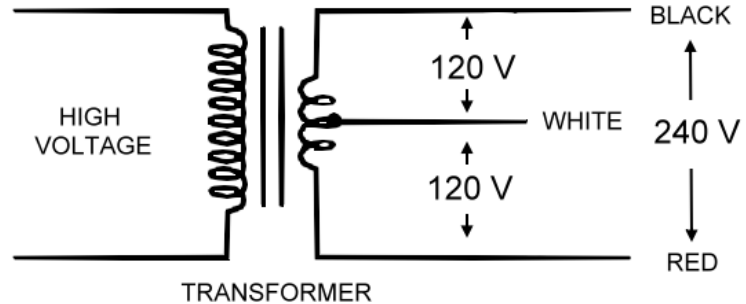
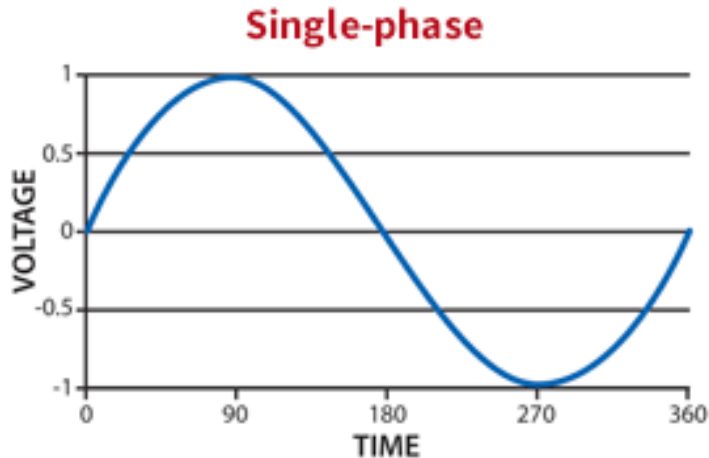

3-Phase Systems

- By using three conductors a three-phase system can provide 173% more power than the two conductors of a single-phase system
- Allows heavy duty industrial equipment to operate more smoothly and efficiently
- Can be transmitted over long distances with a smaller conductor size, making it more economical than single-phase (for low and medium voltage systems)

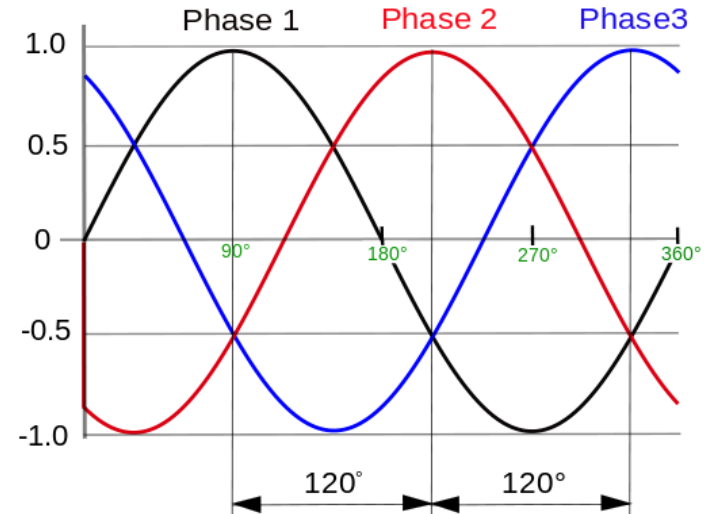

3-Phase, 4-wire Systems

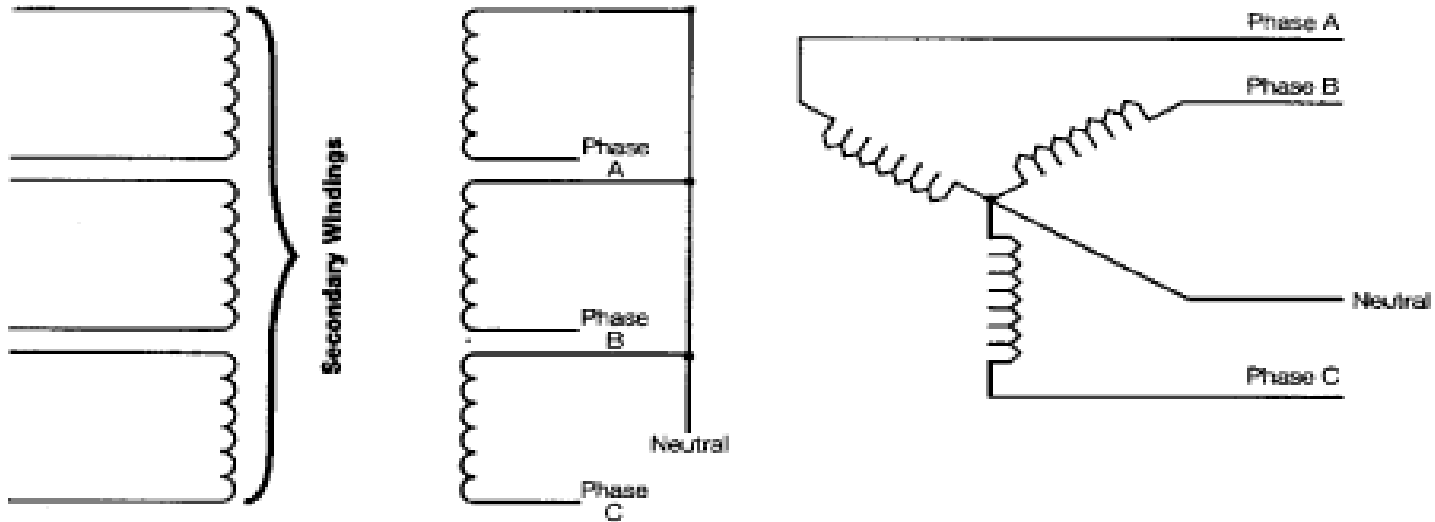

3-Phase, 3-wire Systems

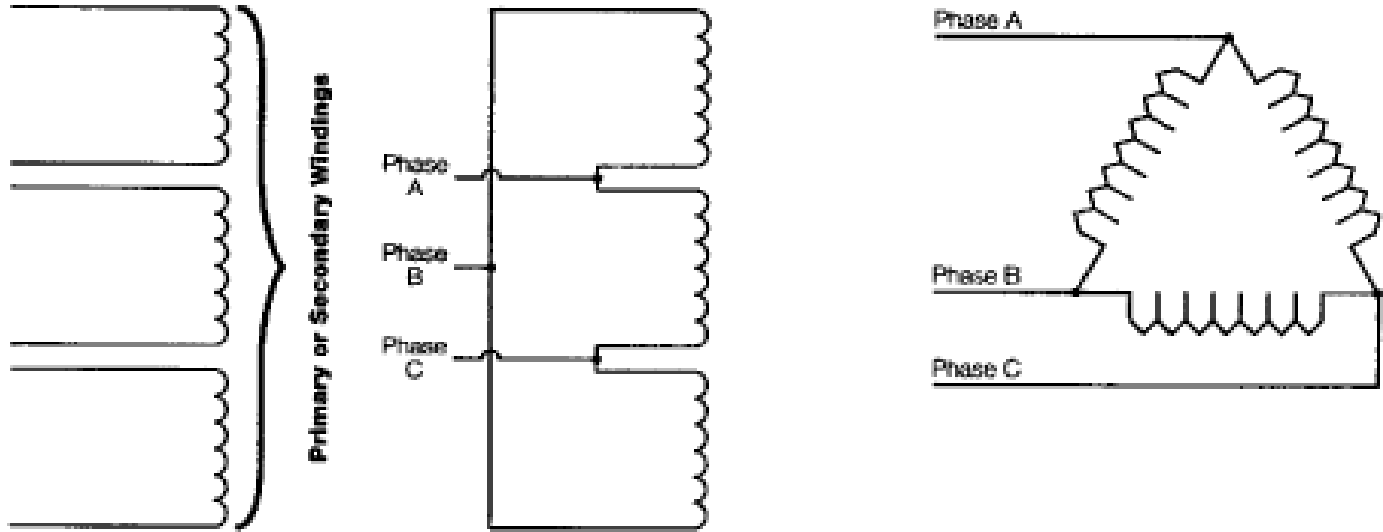

3-Phase Systems Voltages

- Typical 3-phase voltages used in commercial and industrial systems are as follows (phase-to-neutral / phase-to-phase):
 - 120 V / 208 V
 - 277 V / 480 V (U.S.)
 - 347 V / 600 V (Canada)
 - 2400 V / 4160 V

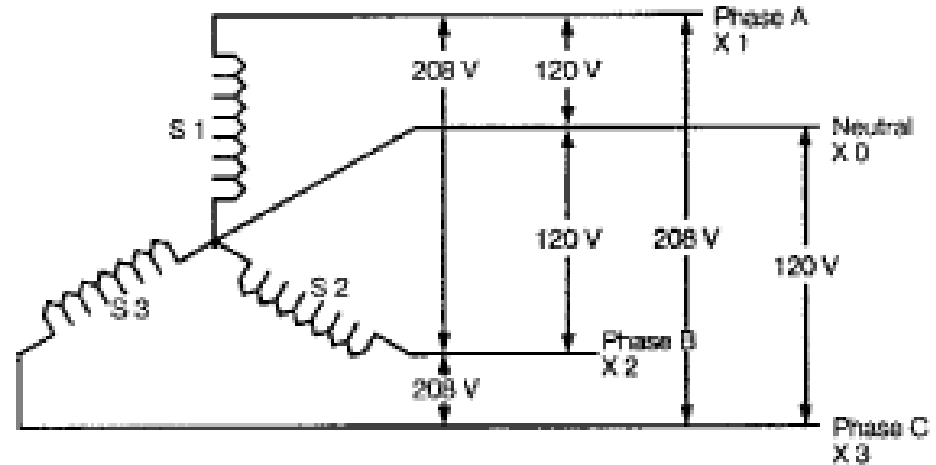

Basics of Wire and Cable Construction

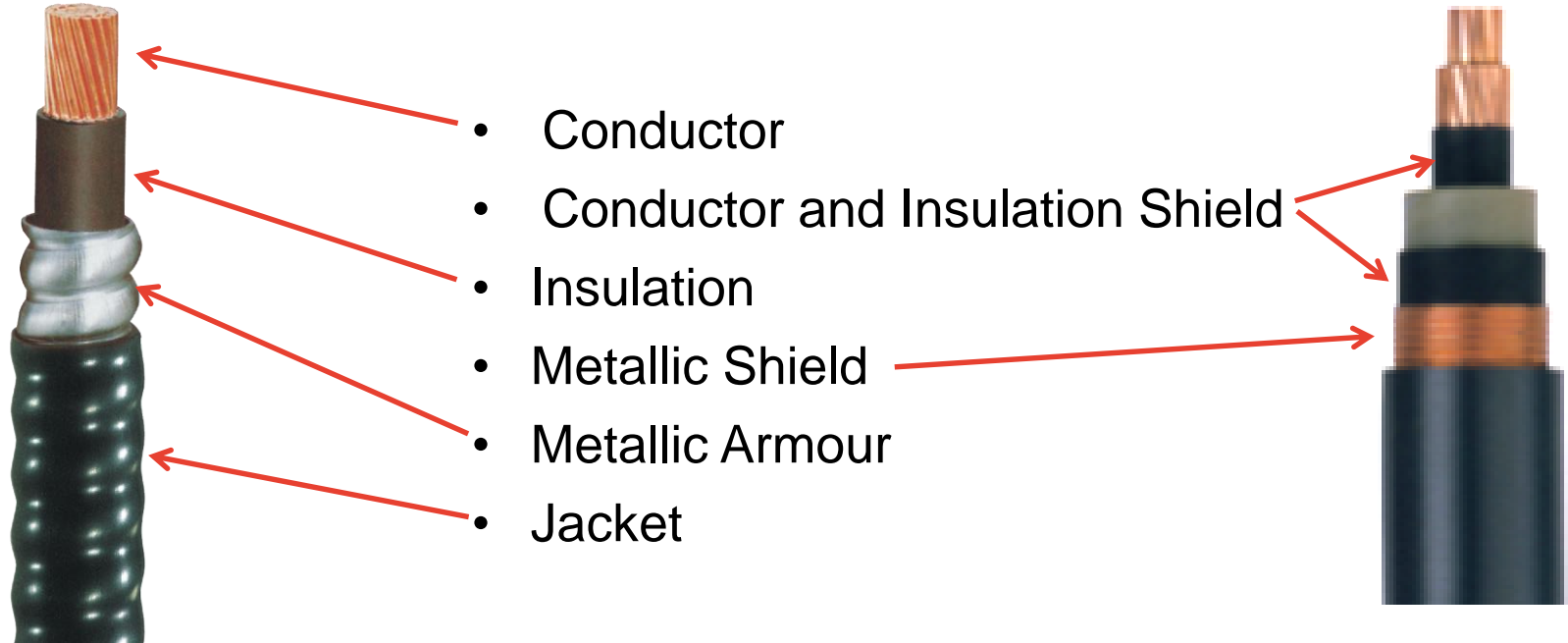

Conductors

- Designed to carry electrical current
- Larger conductor = more current
- Greater number of strands (or wires) = more flexible conductor
- Conductor size is defined by conductor metal cross-sectional area
 - American Wire Gauge (AWG) or circular mils – Canada and U.S.
 - Measure of the diameter
 - AWG is an assigned number for a given conductor size
 - Square millimeters (mm²) – the rest of the world

1 cmil
area

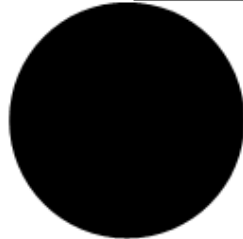

1 mil (0.001 inch)
diameter

Size, AWG or kcmil	mm ²
14**	2.08
12**	3.31
10**	5.26
8	8.37
6	13.3
4	21.2
3	26.7
2	33.6
1	42.4
0	53.5
00	67.4
000	85.0
0000	107
250	127
300	152
350	177
400	203
500	253
600	304
700	355
750	380
800	405
900	456
1000	507
1250	633
1500	760
1750	887
2000	1010

Conductors

- When a conductor carries an electrical current, the resistance of the conductor causes the metal of the conductor to heat
- As the conductor becomes hotter, the resistance increases
- If the conductor is insulated and it gets too hot, the insulation will melt or burn
- Key reason why we must limit the current through a given conductor size
- There are 2 common types of conductor metals used in wire and cable:
 - Copper; and
 - Aluminum



Copper Conductors



- Supplied by Nexans have a purity guaranteed not less than 99.9%, and drawn from copper rod made at our Rod Mill Plant in Montreal
- Commonly supplied in soft temper (annealed)
- Circuit sized conductors (14 AWG to 10 AWG) → solid or stranded
- Power sized conductors (8 AWG to 1000 kcmil) → compressed stranded
- For TECK90 cables: power sized conductors → compact stranded
- May be tinned to resist corrosion or to make soldering easier

Aluminum Conductors

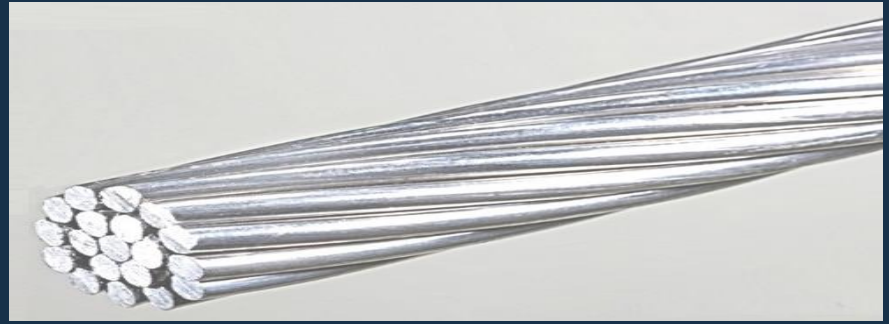

- Building wire systems use an 8000 series alloy, or ACM
- Approximately 61% of the conductivity of copper wire
- All building wire aluminum conductors are soft temper (annealed)
- Power sized conductors (8 AWG to 1000 kcmil) → compact stranded
- Use of aluminum conductors is not as simple as copper
- Some unique installation requirements
- Can save some money on the initial cable purchase, but requires more care in installation

Traditional Stranding



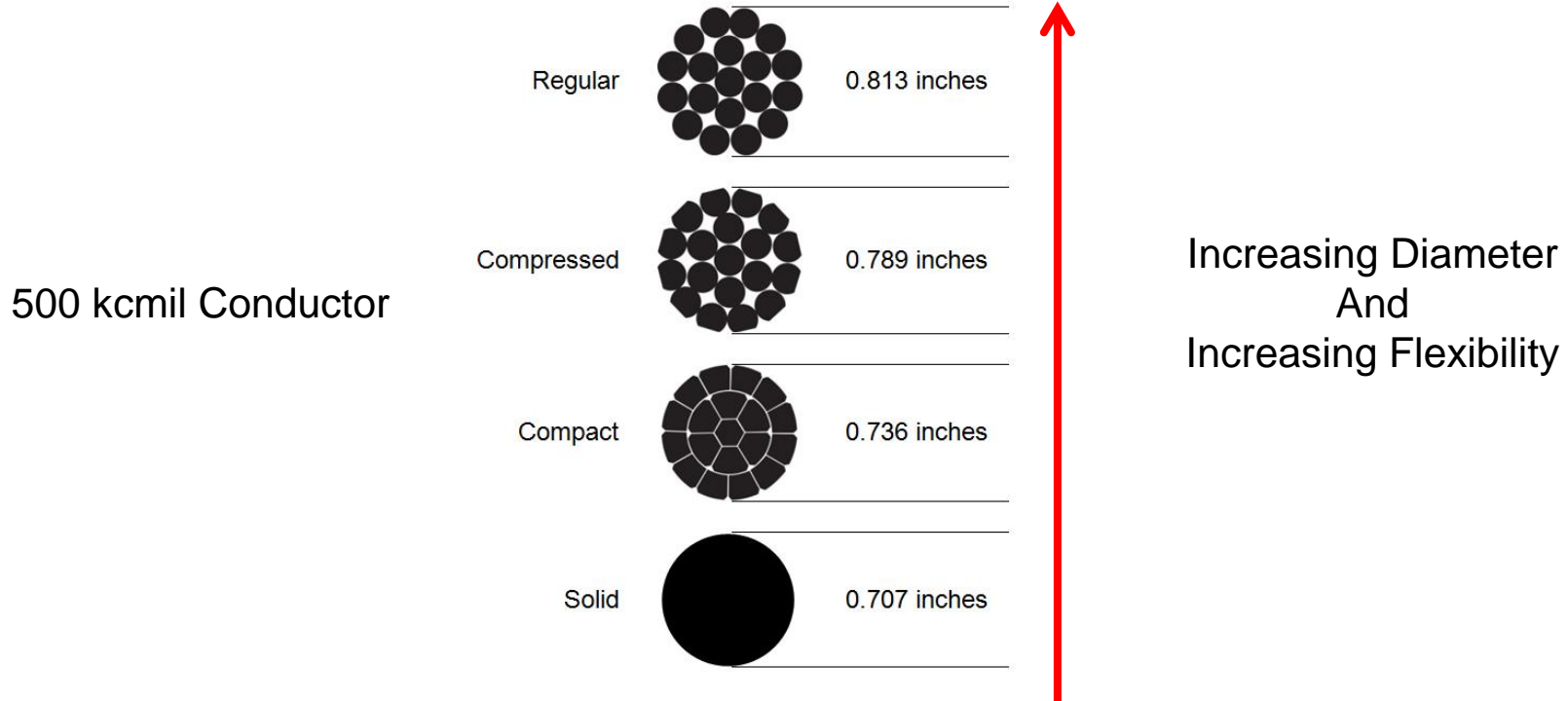







From largest to smallest (diameter):



Single Input Wire (SIW) Stranding

Number of wires used in a compact aluminum conductor

- ASTM B836 (for SIW stranding)
- ASTM B801 (for conventional stranding)

						
Conventional Conductor	Number of Wires	7	18	18	18	18
	Strand Diameter (inches)	0.1057	0.0735	0.0935	0.1050	0.1170
	Overall Diameter (inches)	0.268	0.336	0.376	0.423	0.475
	Conductor Size (AWG)	2	1/0	2/0	3/0	4/0
Single Input Wire (SIW) Conductor	Overall Diameter (inches)	0.268	0.336	0.376	0.423	0.475
	Strand Diameter (inches)	0.1160	0.1160	0.1160	0.1160	0.1160
	Number of Wires	6	10	12	16	19
						

Conductor Insulation

- Main purpose is to save space
- Air is replaced with a material that has a higher dielectric strength
- Must:
 - Withstand: **voltage stresses (voltage spikes); mechanical abuse (abrasion, flexing); and chemical attack (oils, gases)**
 - Operate over a wide temperature range
- Non-conductive (dielectric) material
 - Voltage rating → phase-to-phase voltage
 - Temperature rating → maximum absolute insulation temperature



Conductor Insulation

- Rubber LV
- PVC (Polyvinyl chloride) LV
- PE (polyethylene) LV
- Thermoplastic Elastomer (TPE) LV
- Cross-linked Polyolefine (XLPO) LV, MV
- Ethylene Propylene Rubber (EPR, EPT, EPDM) LV, MV, HV (limited)
- Oil Impregnated Paper MV, HV, EHV
- Cross-linked Polyethylene (XLPE) MV, HV, EHV

LV - Low voltage - 0 - 1000 Volts

MV - Medium voltage - > 1000 V - 46 kV

HV - High voltage - > 46 kV - 230 kV

EHV - Extra high voltage - > 230 kV

Conductor Insulation

Two main types or categories of conductor insulations:

- **Thermoplastic**
- **Thermoset**

Thermoplastic Insulation Systems	Thermoset Insulation Systems
Generally have a lower maximum temperature	
Maximum short circuit temperature of 150°C	Maximum short circuit temperature of 250°C
When overheated, rapidly become liquid, allowing it to flow	When overheated, become somewhat moldable, but will not become liquid

Thermoplastic Insulation

(Up to 5 kV)

PVC (Polyvinylchloride)

- Reasonably good electrical and moisture resistance
- Good flame retardancy and cold temperature characteristics
- Can be modified to enhance various characteristics.



Nylon

- Applied as a thin film (paper thin) over insulations
- Allows the use of thinner insulation walls
- Poor UV resistance
- Resistant to many common chemicals
- Should not be used where acids are present
- Intended to provide the cable with:
 - Mechanical protection → during installation
 - Environmental protection → during use

Thermoset Insulation

(Up to 5 kV)



XLPE (Cross-Linked Polyethylene)

- Very widely used on wire and cable
- Also used for medium and high voltage cables (beyond 46 kV)
- Excellent electrical and mechanical strength and resists moisture
- Good cold weather characteristics
- Must have additives included to be sunlight resistant
- Typical maximum operating temperature of 90°C



EPR (Ethylene Propylene Rubber)

- Widely used in industrial applications
- Synthetic rubbers used on low and medium voltage cables
- Soft and pliable material, good on trailing cable (mines and similar)
- Not as tough mechanically as XLPE
- Typical maximum operating temperature of 105°C

Shielding

Conductor shield, insulation, insulation shield, and metallic shield:

1. Confine the electric field to within the cable
2. Obtain symmetrical radial distribution of voltage stress within the dielectric
3. Protect cable connected to overhead lines or otherwise subject to induced potentials
4. Limit radio interference
5. Reduce the hazard of shock (when properly grounded)

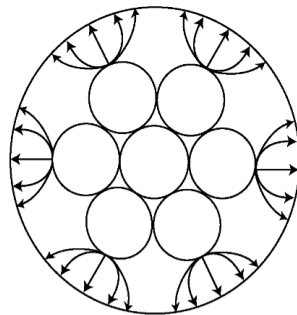

Non-shielded

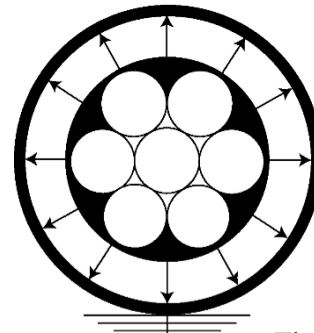

Shielded

Conductor & Insulation Shields

Voltage Range	Shield Type	Metallic Shield
2 kV or Less	No	No
Greater Than 2 kV	Conductor Only	No
5 kV or Greater	Conductor And Insulation	Yes

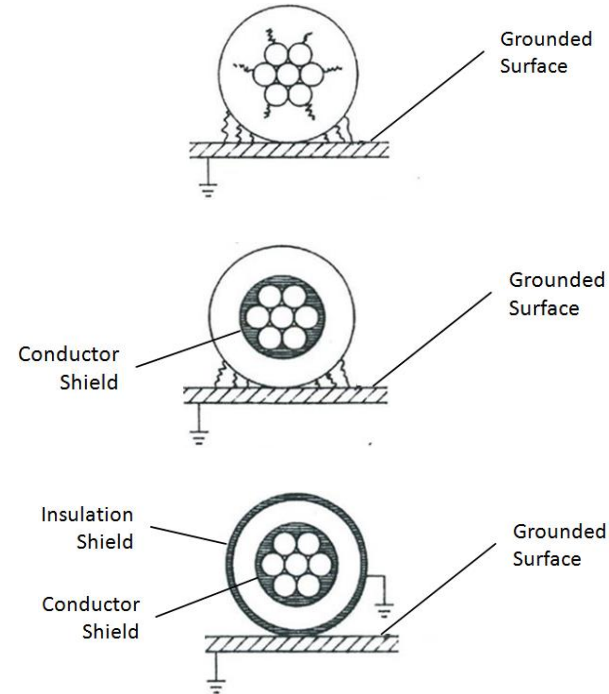

Thermoset Insulation

Shielded Insulation (5 kV and Higher)

TR-XLPE (Tree Retardant Cross-Linked Polyethylene)

- Similar list of features and benefits as the low-voltage XLPE with the added ability to resist the formation of water trees
- Water trees can form in the presence of moisture and electrical stress
- Typical maximum operating temperature of 90°C (105°C possible)



EPR (Ethylene Propylene Rubber)

- Low voltage and medium voltage are very similar



Insulation Level

Shielded Insulation (5 kV and Higher)

Cable insulation level based on fault clearing time of the system:

Fault cleared in one minute or less	100% insulation level
Fault cleared in one minute to one hour	133% insulation level
Fault is cleared after more than one hour	173% insulation level (or next higher voltage class, 100%)

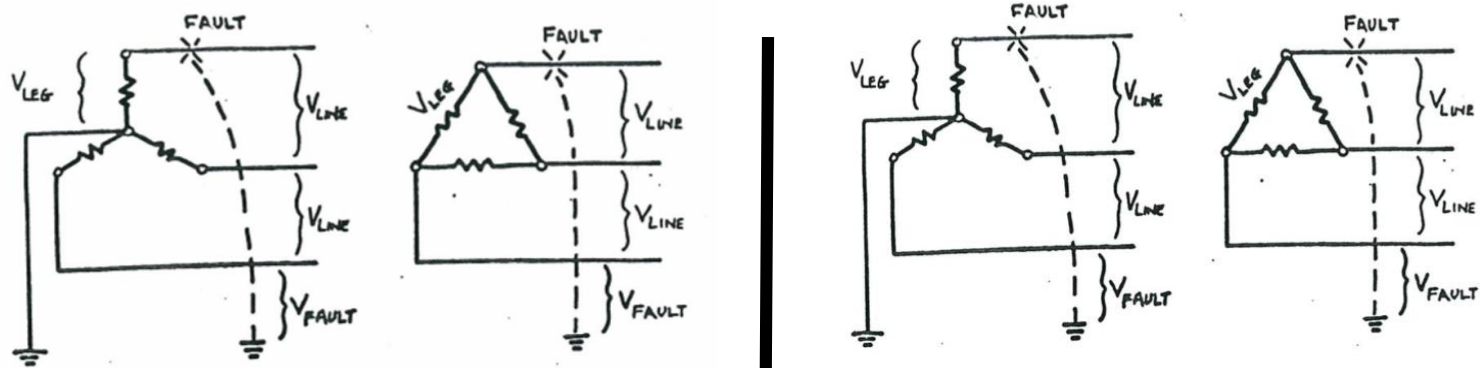

Metallic Shields

Copper Tape – Helically Applied Copper Tape(s)



LACT – Longitudinally Applied Corrugated Copper Tape (CORUSHIELD®)



Concentric Neutral – Helically Applied Wires (6 AWG to 9 AWG)



Wire Shield – Helically Applied Small Wires (22 AWG to 18 AWG)

Used on industrial cables

Used on large single conductor sized utility and industrial cables

Used by utilities on underground distribution cables

Same applications as Cu tape (but very uncommon)

Good electrostatic shield

Good electrostatic shield

1/3 or 33% conductance used on 3 phase systems

Similar short circuit & ampacity derating as copper tape

May be applied with gaps or overlapped

Provides a moisture barrier when longitudinal overlap is sealed

Full or 100% conductance used on single phase system

Not manufactured by Nexans

- Low short circuit capacity.
- If grounded both ends, conductor current derating is small

"Medium" short circuit levels (between helical tape and CN)

- Higher short circuit levels
- Conductor current derating can be high if grounded both ends

Metallic Shields

Metal Sheaths - Lead or Aluminum Sheath or Covering

- Good electrostatic shield/barrier for moisture and chemicals
- High short circuit level and conductor current derating if both ends are grounded
- Sometimes difficult to splice or terminate



Metallic Sheaths & Armours

- Suitable for installations where the cable might be exposed to mechanical damage
- Armoured cables have rugged jackets for direct buried applications
- Manufactured for extreme conditions to withstand the dangers of physical and environmental damage that could be a factor when employed in exposed runs



Metallic Sheaths & Armours

Interlocked Metallic Armour



Wrap a formed tape over the cable

Typically aluminum, but can be galvanized steel

Cannot be used as a bonding conductor

More flexible than continuous sheath

Can be broken open if bent too sharply

Will allow moisture to penetrate to core

Usually supplied with an outer covering

Used on AC90, ISO-BX, ACWU90, FIREX[®]
TECK90, and FIREX[®] MV Shielded Power cables

Continuous Metallic Armour



Welded tube (usually corrugated) over the cable

Typically aluminum

Can be used as a bonding conductor

Corrugated for flexibility

Can be damaged if bent excessively

Will not allow moisture to penetrate to core

Usually supplied with an outer covering

Used on CORFLEX[®] RA90, DriveRX[®] VFD

Jackets and Coverings

- Purpose is to protect the cable from the environment. (i.e. moisture, sunlight, fire, chemicals, etc.)
- In Canada, jackets are required to remain bendable at low temperatures without cracking.
- Most common materials used for power cables are Polyethylene (PE), or Polyvinyl Chloride (PVC)



Jackets and Coverings



PE – Polyethylene

- Tough and water-resistant
- Does not have good flame resistance
- Resistant to many common chemicals
 - Acids
 - Alkalis
 - Some oils



PVC – Polyvinylchloride

- Often modified to enhance physical characteristics
- Tough, sunlight resistant, can have FT1 or FT4 flame spread rating
- Resistant to many common chemicals
 - Acids
 - Alkalis
 - Most oils

Selecting the Right Cable

Utility – Transmission & Distribution

Industrial

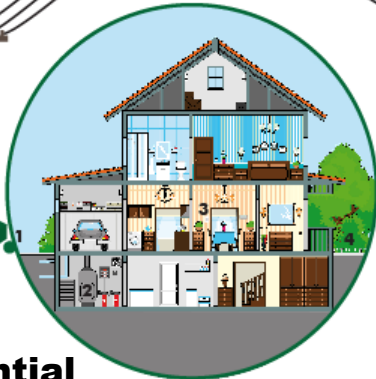
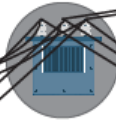
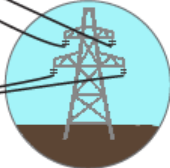
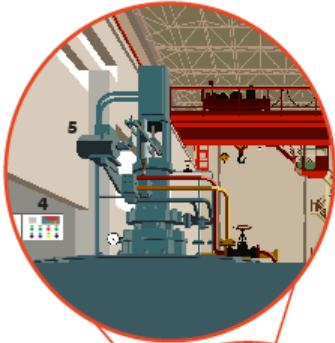

Residential

Commercial

Utility - Transmission & Distribution

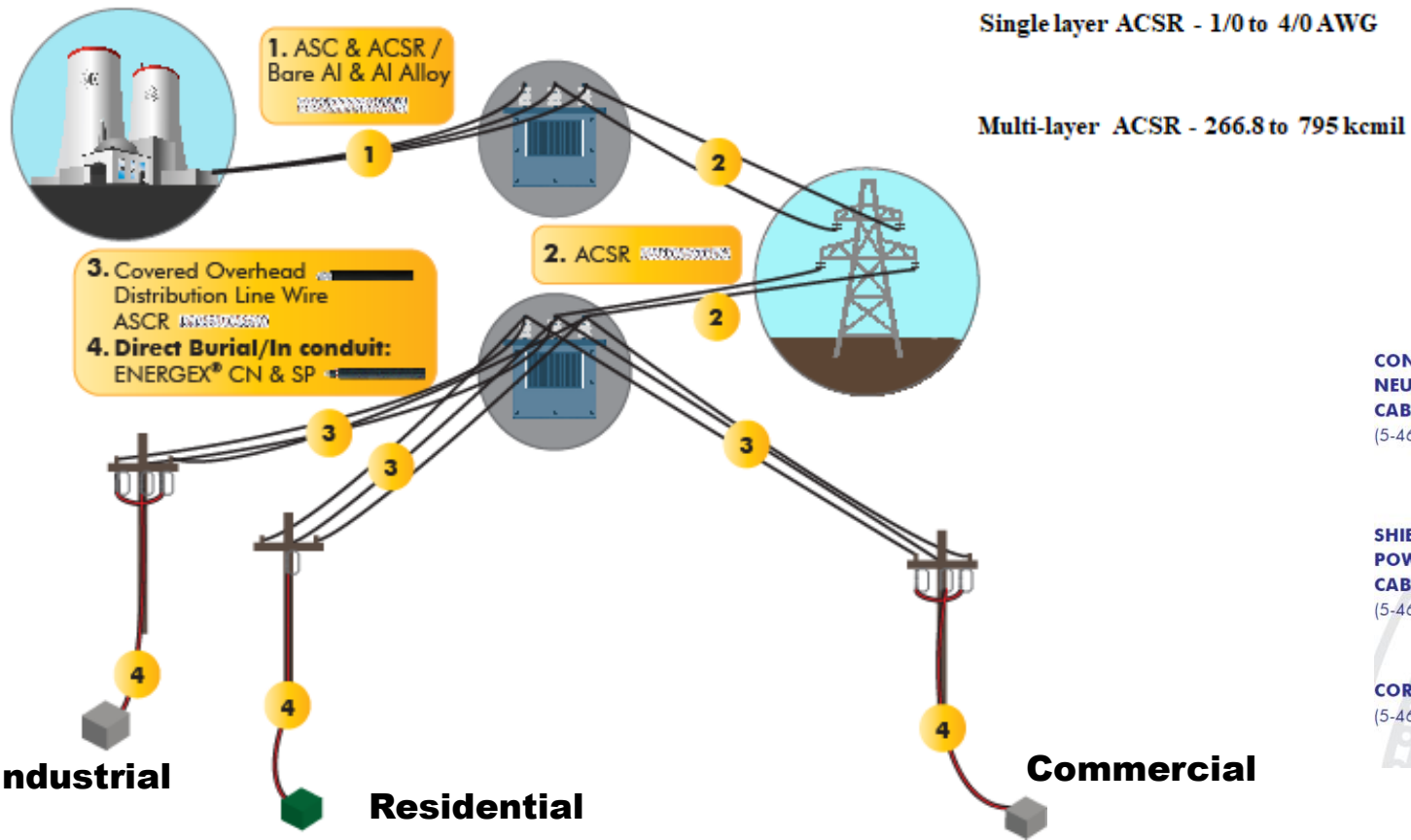

Single layer ACSR - 1/0 to 4/0 AWG



Multi-layer ACSR - 266.8 to 795 kcmil

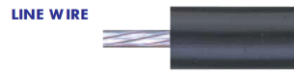

CONCENTRIC NEUTRAL CABLE
(5-46 kV)



SHIELDED POWER CABLE
(5-46 kV)



CORU-SHIELD®
(5-46 kV)

Industrial

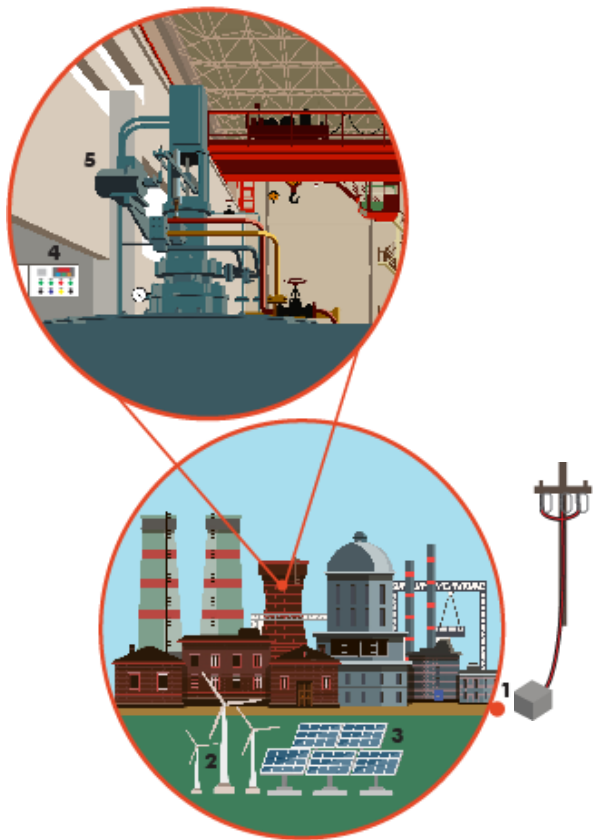

1. Service Entrance:

Overhead: NS75 & NS90

In Conduit: INSTAGLIDE® RW90/RWU90

Direct Burial: ACWU90

CORFLEX® RA90

FIREX® TECK90

INSTAGLIDE® RWU90

Medium Voltage Armoured Power Cables

2. **Wind:** ENERGEX® CN Medium Voltage 90°C or 105°C

3. **Solar:** RPVU90 Solar/Photovoltaic

4. **Power & Control:** ACWU90

Bare Copper

CORFLEX® RA90

INSTAGLIDE® T90/TWN75 & RW90/RWU90

FIREX® TECK90

Medium Voltage Armoured Power Cables

5. **VFD:** DriveRx® VFD

Commercial

1. Service Entrance:

Overhead: NS75 & NS90 

In Conduit: INSTAGLIDE® RW90/RWU90 

Direct Burial: ACWU90 

CORFLEX® RA90 

FIREX® TECK90 

INSTAGLIDE® RWU90 

TWU 

2. Power & Control:

INSTAGLIDE® T90/TWN75 & RW90/RWU90 

3. HVAC: Bare Copper 

DriveRx® VFD 

4. Lights & Power: AC90 

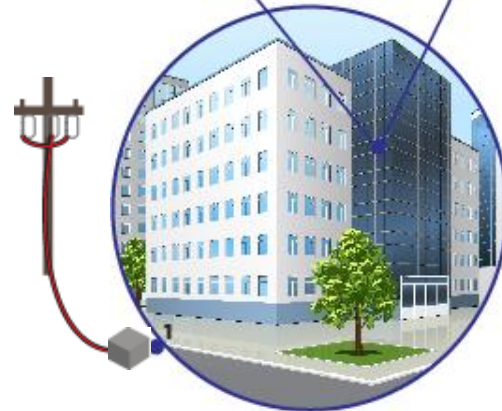

Residential

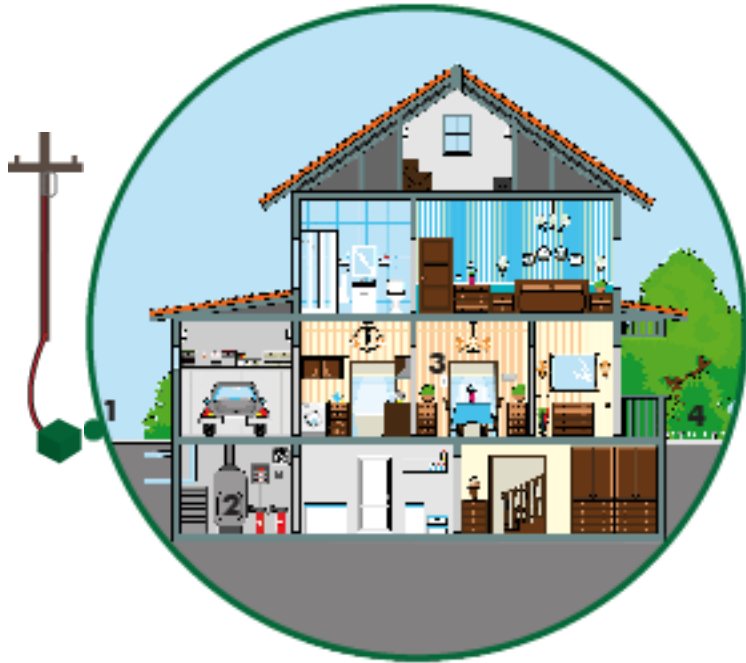

1. ● Service Entrance:

Overhead: NS75 & NS90 

Direct Burial: ACWU90 

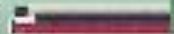
USEI75 & USEI90 & USEB90 

2. Heating & A/C: AC90

HEATEX® NMD90 

3. Lights/Appliances: CANADEX® NMD90

4. Landscape: SUPERVEX® NMWU



Key Takeaways

- **ELECTRICITY:** form of energy that can occur naturally or can be produced.
- People have been able to put this form of energy to good use by creating **ELECTRICAL SYSTEMS** connecting the world.
- **CABLE:** transmit and distribute electricity
 - **CONDUCTOR:** carry electric current.
 - **INSULATION:** must withstand voltage stresses.
 - **SHIELDS:** confine the electric field to within the cable and provide mechanical protection.
 - **JACKETS:** protect the cable from the environment.
- **CABLE SELECTION** involves understanding the cable's intended purpose, identifying the location of installation, and deciding on the desired cable characteristics (features/ratings).

Q & A

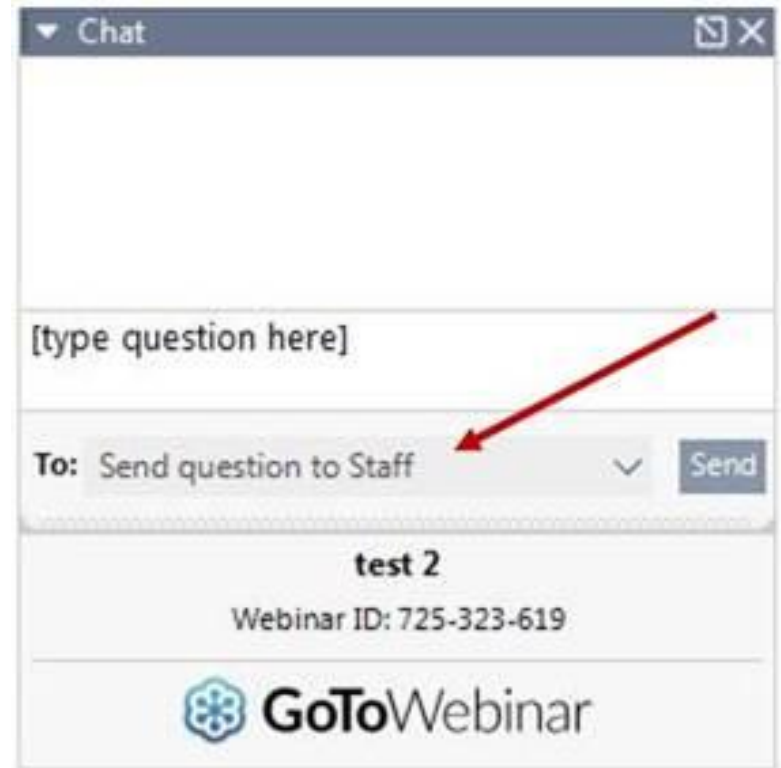

Thank you for your attention!

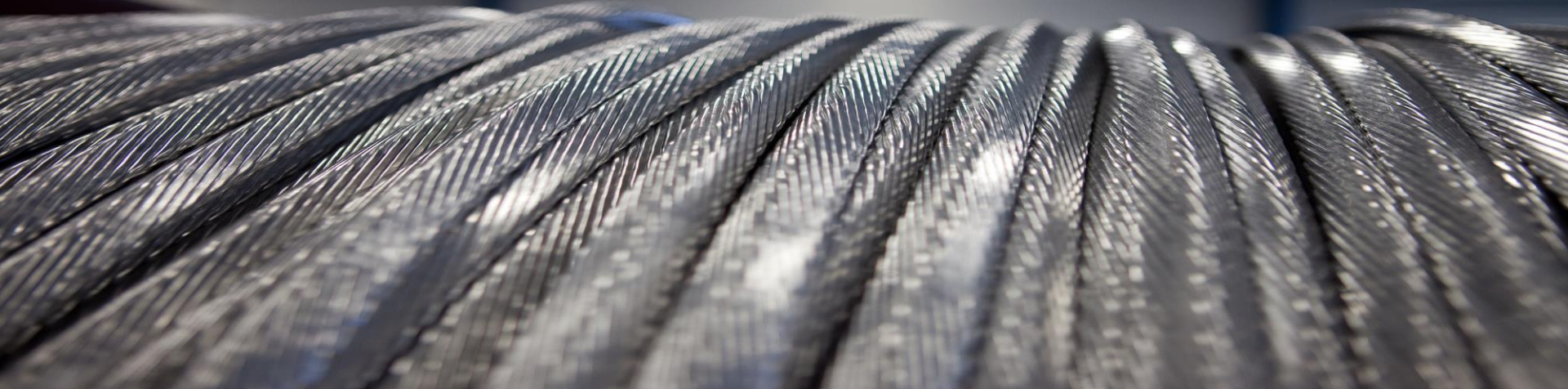

Contact:

Wissam Geahchan

Applications Engineer, Nexans Canada
wissam.geahchan@nexans.com

www.nexans.ca



Nexans
ELECTRIFY THE FUTURE